

Seismic Equipment Rail

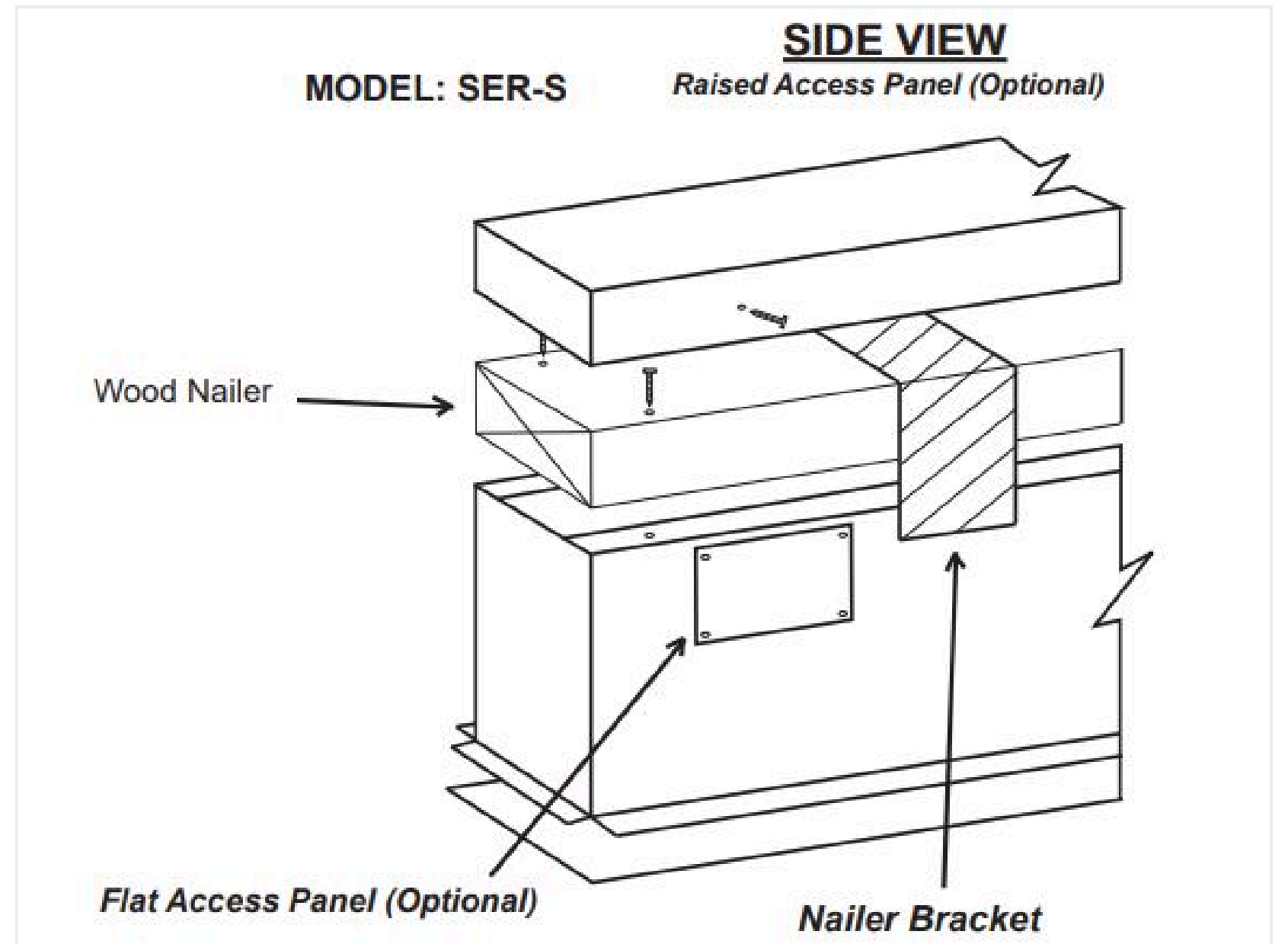
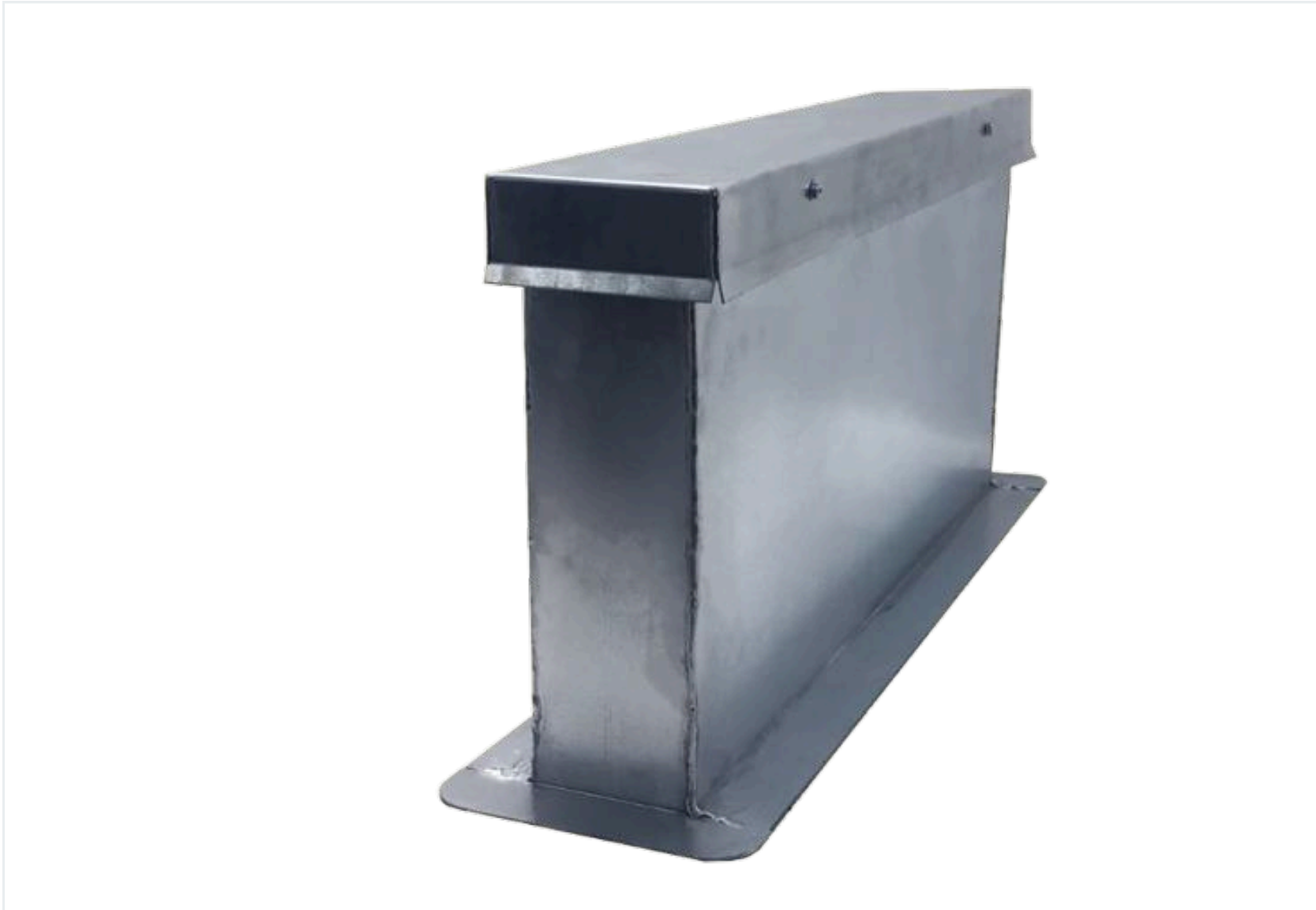

Standard Product Features

- ✓ 14 GA. Welded Galvanized Metal
- ✓ 8" and 12" Standard Height (H)
- ✓ Patented Interior Bulkhead Reinforcement
- ✓ 2" x 4" Wood Nailer
- ✓ Welded Corner Seams
- ✓ Nailer Brackets

Optional Product Features

- ✓ Stainless Steel Construction
- ✓ Heavier Material Gauges (10-12 GA.)
- ✓ Wood Nailers in Widths (W) up to 2" x 12"
- ✓ Chemically Treated Wood Nailers
- ✓ Unit Lengths up to 24 Feet
- ✓ Custom Heights (H)
- ✓ Construction to Fit Pitched Roofs
- ✓ Nailer Brackets
- ✓ Flat Access Panel
- ✓ Raised Access Panel (Allows For Future Inspection)

