

Metal Building Curb

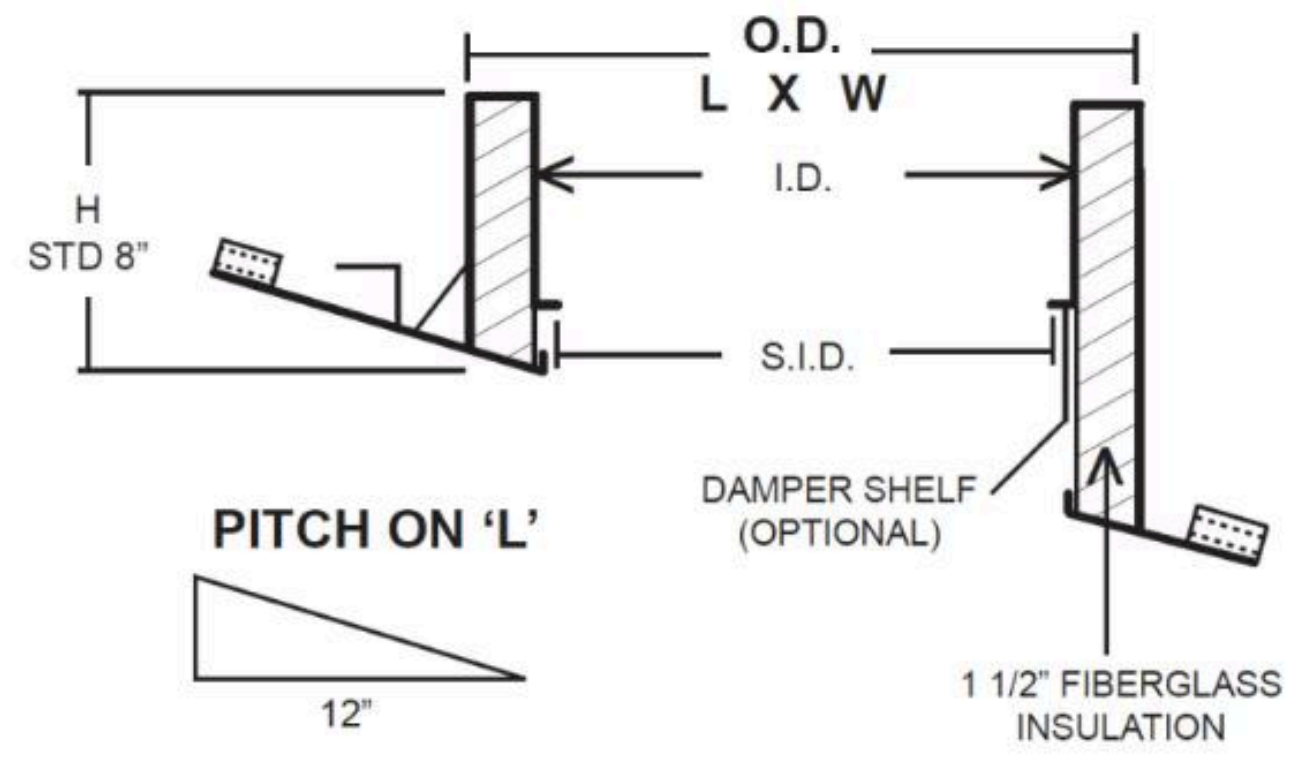

Standard Product Features

- ✓ 18 GA. Welded Galvanized Steel Construction
- ✓ 1 1/2" X 3lb Density Fiberglass Insulation
- ✓ 8" Standard Height
- ✓ Built-In Cricket
- ✓ Welded Corner Seams
- ✓ Neoprene Gasket 1.5" X 1/4"
- ✓ Rib Conforming Notches

Optional Product Features

- ✓ Rain Diverter 3/4" X 2"
- ✓ Additional Height
- ✓ Uninsulated
- ✓ Aluminum Construction
- ✓ Additional Reinforcement Based on Size

